

Centrifugal pumps

Model CG

Sectional Drawing

Description

Vertical in-line single stage pump in single suction impeller, radially split casing with flexible spacer coupling and hydrodynamic sleeve bearing.

Capacity: 30-1100 m³/h

Differential pressure: 15-120 mlc.

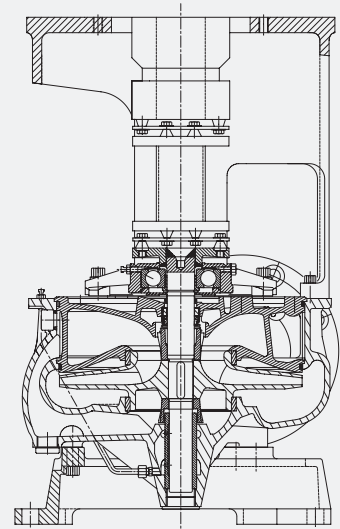

Technical specification

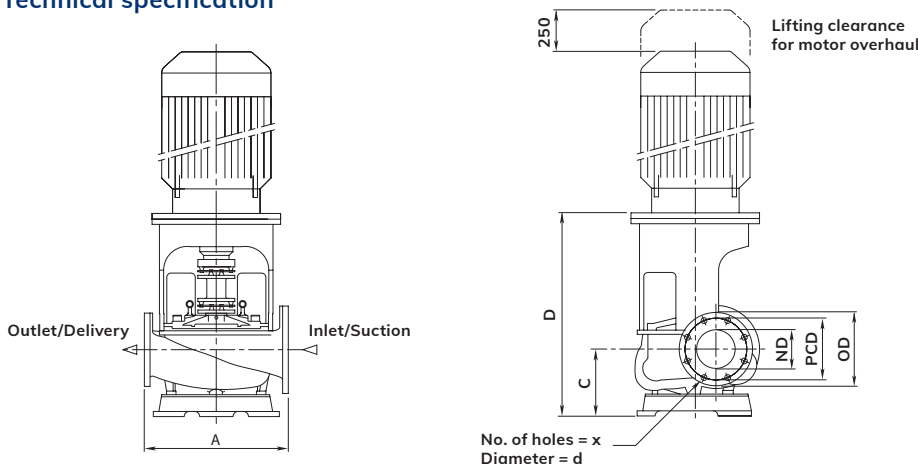

Dimensions (mm)

Pump Size	Flange Dimensions to DIN2501 Pressure rating 10 bar										Dimensions			Weight* (kg)
	Delivery flange					Suction flange					A	C	D	
	ND	OD	PCD	d	x	ND	OD	PCD	d	x				
CGA 50	50	165	125	18	4	65	185	145	18	4	420	195	578	110
CGA 65	65	185	145	18	4	80	200	160	18	8	420	196	584	120
CGB 80	80	200	160	18	8	100	220	180	18	8	450	218	643	130
CGB 100	100	220	180	18	8	125	250	210	18	8	450	224	657	145
CGC 125	125	250	210	18	8	150	285	240	22.5	8	500	247	744	165
CGC 150	150	285	240	22.5	8	200	340	295	22.5	8	560	260	768	185
CGD 200	200	340	295	22.5	8	250	395	350	22.5	12	630	332	970	215
CGD 250	250	395	350	22.5	12	300	445	400	22.5	12	710	382	1020	260
CGE 300	300	445	400	22.5	12	350	505	460	22.5	16	800	490	1257	320
CGE 350	350	505	460	22.5	16	400	565	515	26.5	16	900	560	1327	410

*Approximate Weight

Construction code

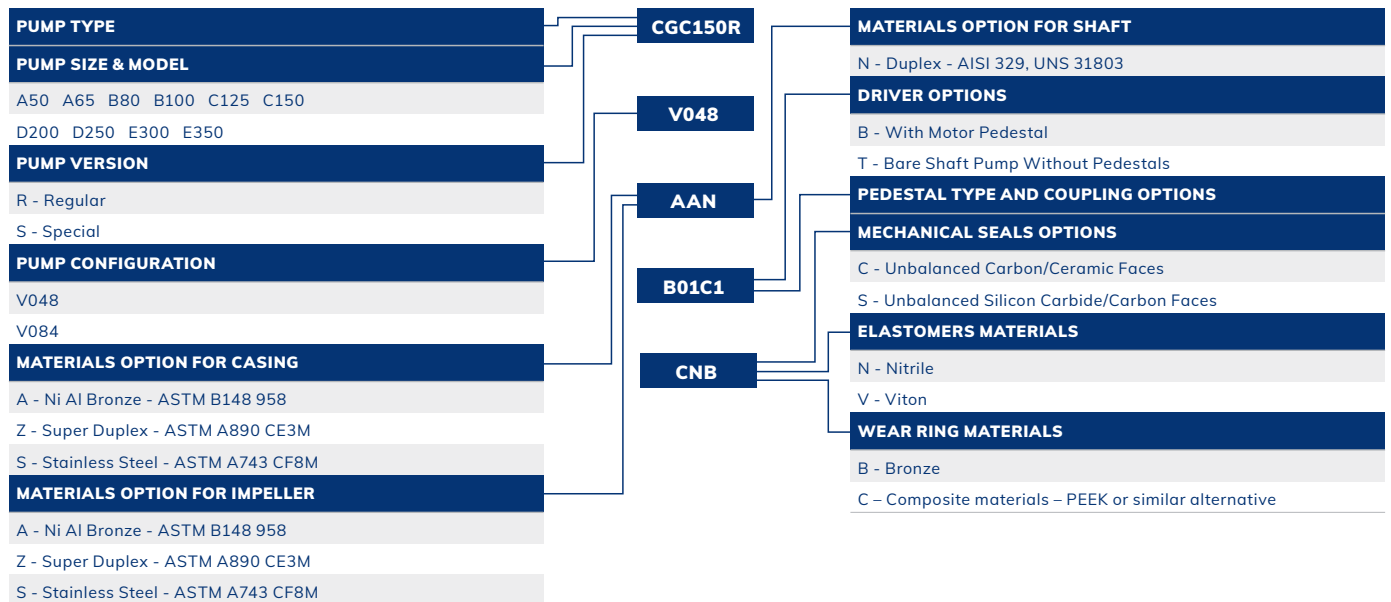

NOTE: For casings and impellers various additional material options may be available on request. e.g. other grades of bronze, Duplex, Nodular Cast Iron etc. For shafts various materials available on request e.g. Monel, Super Duplex - UNS32760 etc. For driver options others transmission devices e.g. gear coupling available on request. Other coupling options are available on request. Various mechanical seal options available on request e.g. balanced seal, harden faced seal faces, Hastelloy metals parts etc. For elastomers materials other options available on request e.g. EPDM. Product lubricated sleeve bearing is available on request.

Pump configuration

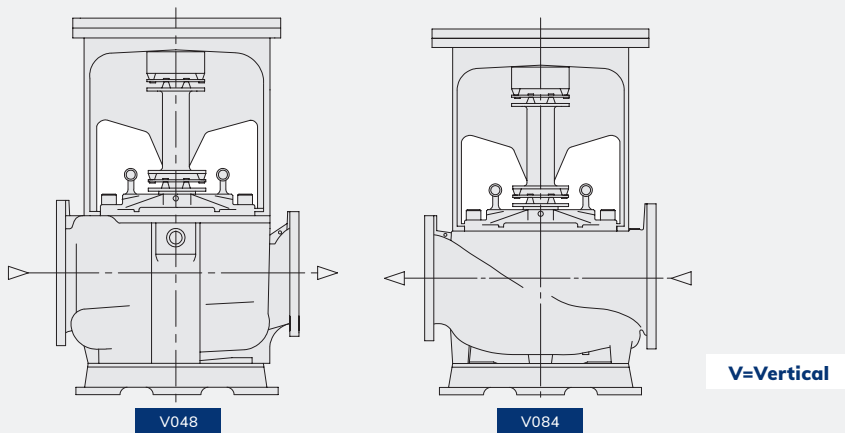

Capacity range

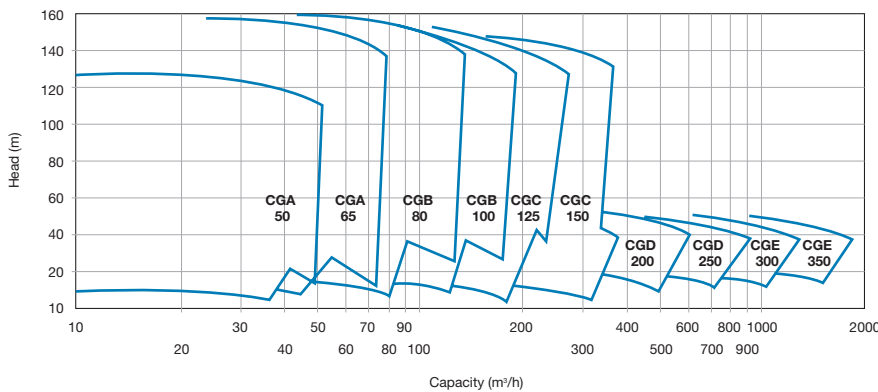

The manufacturers reserve the right to alter the specification and data to incorporate improvements in design. Certified drawings will be issued on request.

© All details copyright Hamworthy Pumps

Website: www.hamworthy-pumps.com

Hamworthy Pumps

Hamworthy Pumps Singapore Pte Ltd
Tel: +65 6261 6066
Email: sgpumpsales@hamworthy-pumps.com

Hamworthy Pumps UK Ltd
Tel: +44 (0) 788 6851102
Email: gbpumps@hamworthy-pumps.com